



Brookstone®

VR HEADSET

WITH BUILT-IN HEADPHONES

TABLE OF CONTENTS

Cautions and Warnings	1
Location of Parts and Controls	5
Using the VR Headset.....	6
Compatible Phones.....	10
Headset Specifications	10
Frequently Asked Questions	11
Warranty.....	12

SAVE THESE INSTRUCTIONS

IMPORTANT SAFETY INSTRUCTIONS

When using this headset, basic precautions should always be followed.

Read all instructions before using. Safety and operating instructions should be followed each time the headset is used.

⚠ WARNING

Close supervision is necessary when this product is used by or near children or mentally disabled individuals.

- Use this unit only for its intended use as described in this manual.
- The unit should be situated away from direct sunlight or heat sources such as radiators, electric heaters, heat registers, stoves, or other units (including amplifiers) that produce heat. Avoid placing on top of stereo equipment that radiates heat.
- Immediately discontinue use of the headset if you experience any of the following symptoms or other physical or psychologic symptoms: motion sickness, nausea, disorientation, dizziness, lightheadedness, eyestrain, blurred vision or other visual abnormalities, stress, anxiety, seizures, loss of awareness, eye or muscle twitching, involuntary movements, impaired balance, impaired eye-hand coordination, excessive sweating, increased salivation, discomfort or pain in the head or eyes, drowsiness, or fatigue.

- NEVER look at the sun through the headset. If you are wearing the headset with no phone and accidentally look at a powerful light, you risk damaging your vision.
- Keep the volume of your headset at a safe level. Prolonged periods of loud noise can lead to ear damage including reduced hearing and tinnitus.
- Do not use for longer than 15 minutes at a time and remove the headset for at least 15 minutes prior to next use.
- To avoid visually triggered symptoms such as headaches and nausea, ensure your phone is aligned correctly.
- Never leave your headset face down (lenses up) or outside. If the sun shines on the lenses at the wrong angle, it can focus the rays onto your phone screen, possibly ruining the screen of your phone.
- For a minimum of 30 minutes after using the headset, do not drive, operate machinery, or engage in other visually or physically demanding activities that have potentially serious consequences (activities in which experiencing any symptoms could lead to death, personal injury, or damage to property), or other activities that require unimpaired balance and hand-eye coordination, such as playing sports or riding a bicycle, etc.

⚠ WARNING - USER RESTRICTIONS

Use of a virtual reality headset is not suitable for everyone. Adhere to the following restrictions:

- Not for use by persons under 14. Watching videos or playing games with a virtual reality headset may affect the visual development of children. Prolonged use should be avoided, as this could negatively impact eye-hand coordination, balance, and multi-tasking ability. Adults should monitor children closely during and after use of the headset for any decrease in these abilities and for any signs of discomfort.
- Do not use the headset if you are under the influence of drugs or alcohol, are suffering the after effects of using drugs or alcohol, are overly tired, or are suffering from a cold, headache, upset stomach, or other sickness. These conditions can make you more susceptible to the discomfort and disorientation that can be caused by virtual reality.
- Consult your physician before use if you are pregnant, elderly, suffer from vision abnormalities, seizures, epilepsy, psychiatric disorders, heart conditions or other medical conditions.
- If you have ever had severe dizziness, blackouts, seizures, or any symptoms of epilepsy, consult a physician before using the headset. Flashing images and repetitive sequences viewed through the headset could cause seizures, even in those who do not have a history of seizures.
- People who wear an implanted medical device such as a pacemaker should consult a doctor prior to using the headset; the phone used with the

headset may emit radio waves which could interfere with the normal operations of such devices.

- If you have any doubt about whether use of a virtual reality headset is appropriate for you, consult your doctor.

⚠ WARNING - LOCATION RESTRICTIONS

When using the headset, your vision is obscured and your ability to hear what is happening in your surroundings is limited. Adhere to the following restrictions:

- Remain seated or stationary at all times while using the headset.
- Do not use the headset near balconies, stairwells, breakable or sharp objects, or in potentially dangerous surroundings
- Do not use the headset while engaged in an activity that may require your immediate attention.
- Do not attempt to walk, run, drive, or change your location in any way while using the headset.
- Use the headset only indoors in a controlled environment.
- Take steps to prevent pets, children, other people, or obstacles from entering the area during use. You may be unaware of their presence and accidentally harm those in your immediate area.
- For the most comfortable viewing experience, sit in a slightly reclined position, leaning back between a 45° and 60° angle.

SAVE THESE INSTRUCTIONS!

LOCATION OF PARTS AND CONTROLS

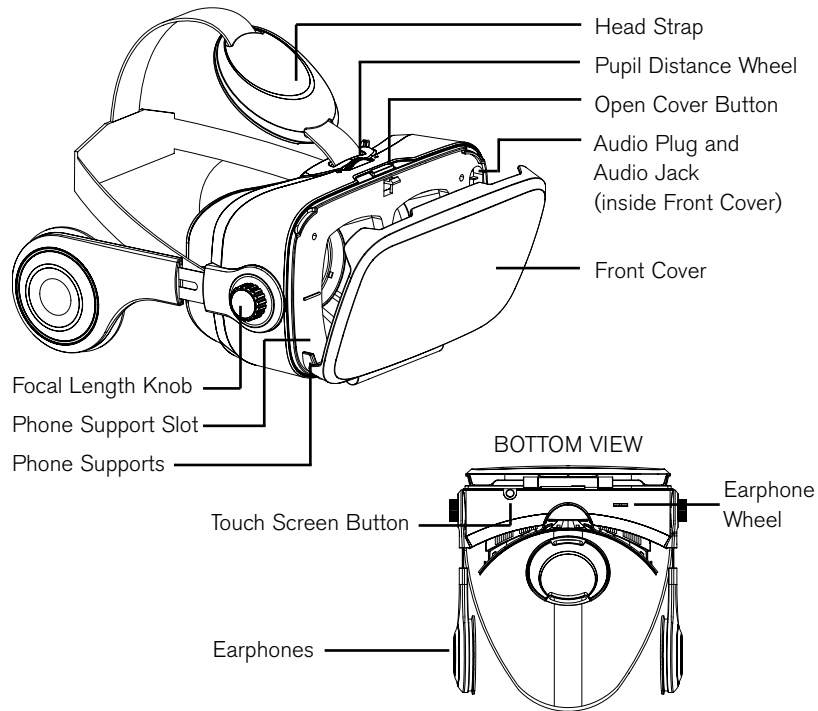

USING THE VR HEADSET

1. Launch a virtual reality app on your smart phone. (Refer to page 10 for information on supported phones.)
2. Some virtual reality apps require pairing with your headset to correctly calibrate visual effects. Follow the directions provided by your app for pairing. If prompted, align the following QR Code within the corner markers displayed by your app. When pairing is complete, the headset identifier will display and the phone will enter double-screen mode.



3. On the VR Headset, press the Open Cover Button to open the front cover.
4. Remove the Audio Plug from the headset's Audio Jack and insert it into your phone's audio jack.
5. Slide the Phone Supports to their widest position.

6. Rotate your phone so the Settings gear in your app displays at the bottom of the screen and the phone's screen is pointed toward the headset's eyepieces.
7. Place your phone into the Phone Support Slot, placing the Audio Plug behind the phone support spring.
8. If necessary, slide the Phone Supports to create a snug fit for your phone.
9. Close the headset's Front Cover.
10. Loosen the Head Strap, place the headset on your head, adjust the strap for a comfortable fit, and refasten the strap.
11. Adjust the earphones to fit comfortably over your ears.

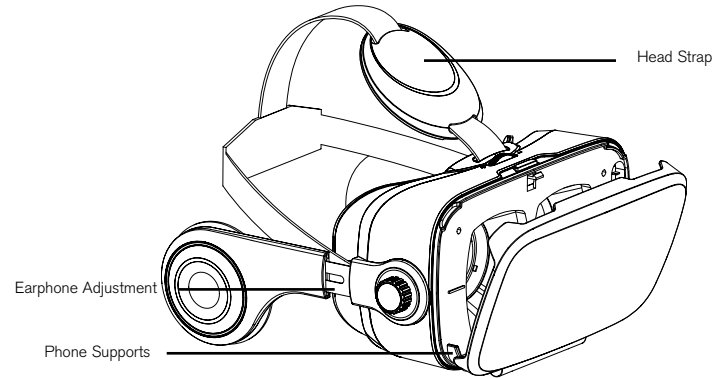

12. To adjust the focal distance, turn the Focal Length Knobs on the right and left sides of the headset to bring your app into focus.
13. To adjust the pupil distance, turn the Pupil Distance Wheel, located on the top of the headset, to eliminate the double image.

Note: Many visually impaired users find that they do not need to wear glasses with the headset. Try adjusting the focal length without your glasses. If you are unable to focus properly, try again while wearing your glasses.

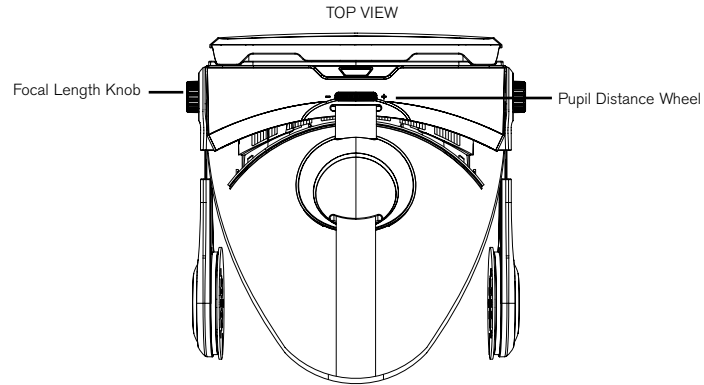

14. The Earphone Wheel, located under the left eye cup, controls earphone function.
 - To adjust the volume, turn the Earphone Wheel left or right.
 - To answer a call, press the Earphone Wheel.
 - To play the next song, double press the Earphone Wheel.
15. Press the Touch Screen Button, located under the right eye cup, to interact with your app. The function of the Touch Screen Button is determined by your app.

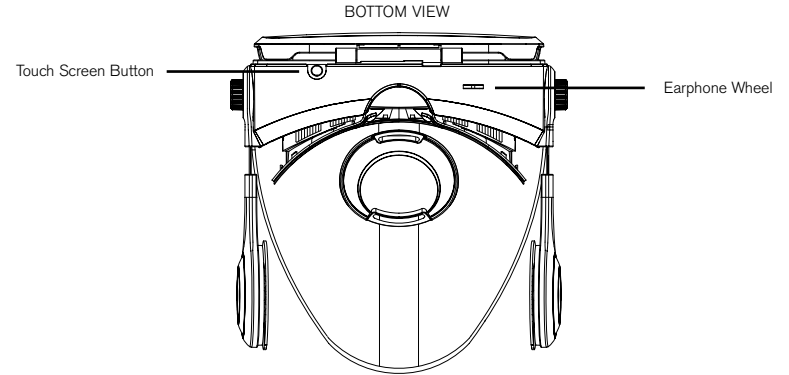

16. To end your session with the VR Headset, press the Open Cover Button, remove your phone, remove the Audio Plug from your phone's audio jack and re-insert it into the headset's Audio Jack. Close the front cover.

COMPATIBLE PHONES

The VR Headset can be used with phones conforming to the following specifications:

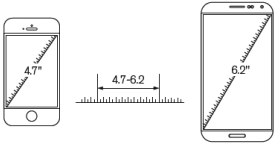
Phone Size	<p>4.7 to 6.2 inch diagonal screen size</p> <p>Maximum total phone size: 3.26 by 6.49 inches (83 by 165 mm)</p> 
Operating System	Android®, iOS®

HEADSET SPECIFICATIONS

Product Weight 14.5 oz
 Product Dimensions 8.5 x 7.7 x 4.7 in
 Field of Vision 120°
 Anti-fog lens Clean with provided cloth

© Brookstone 2017

FREQUENTLY ASKED QUESTIONS

Why is the display out of focus?

Use the Focal Length Knobs and the Pupil Distance Wheel to focus the headset.

If you wear glasses, try focusing with and without your glasses to achieve the best result.

Ensure that your phone is correctly positioned in the Phone Support Slot, with the Settings gear displayed at the bottom of the screen.

Ensure that your app is correctly paired with the headset, if required, as described on page 6.

Why can't I hear the audio played by my app?

Ensure that the headset's Audio Plug is securely inserted into your phone's audio jack.

Adjust the volume on your phone.

Use the Earphone Wheel, located under the left eye cup, to adjust the volume on the headset.

ONE (1) YEAR LIMITED WARRANTY

Brookstone® warrants this product against defects in materials and/or workmanship under normal use for a period of ONE (1) YEAR from the date of purchase by the original purchaser ("Warranty Period"). If a defect arises and a valid claim is received within the Warranty Period, at its option, Brookstone will either 1) repair the defect at no charge, using new or refurbished replacement parts, or 2) replace the product with a new product that is at least functionally equivalent to the original product, or 3) provide a store credit in the amount of the purchase price of the original product. A replacement product or part, including a user-installable part installed in accordance with instructions provided by Brookstone, assumes the remaining warranty of the original product. When a product or part is exchanged, any replacement item becomes your property and the replaced item becomes Brookstone's property. When a store credit is given, the original product must be returned to Brookstone and becomes Brookstone's property.

Obtaining Service: To obtain warranty service, call Brookstone Limited Warranty Service at 1-800-292-9819. Please be prepared to describe the product that needs service and the nature of the problem. A purchase receipt is required. All repairs and replacements must be authorized in advance. Service options, parts availability and response times will vary. You are responsible for delivery and the cost of delivery of the product or any parts to the authorized service center for replacement, per our instructions.

Limits and Exclusions: Coverage under this Limited Warranty is limited to the United States of America, including the District of Columbia and the U.S. Territories of Guam, Puerto Rico, and the U.S. Virgin Islands. This Limited Warranty applies only to products manufactured for Brookstone that can be identified by the "Brookstone" trademark, trade name, or logo affixed to them or their packaging. The Limited Warranty does not apply to any non-Brookstone products. Manufacturers or suppliers other than Brookstone may provide their own warranties to the purchaser,

but Brookstone, in so far as permitted by law, provides these products "as is." This warranty does not apply to: a) damage caused by failure to follow instructions relating to product's use or the installation of components; b) damage caused by accident, abuse, misuse, fire, floods, earthquake or other external causes; c) damage caused by service performed by anyone who is not a representative of Brookstone; d) accessories used in conjunction with a covered product; e) a product or part that has been modified to alter functionality or capability; f) items intended to be periodically replaced by the purchaser during the normal life of the product including, without limitation, batteries or light bulbs; g) any product sold "as is" including, without limitation, floor demonstration models and refurbished items; or h) a product that is used commercially or for a commercial purpose.

BROOKSTONE SHALL NOT BE LIABLE FOR INCIDENTAL OR CONSEQUENTIAL DAMAGES RESULTING FROM THE USE OF THIS PRODUCT, OR ARISING OUT OF ANY BREACH OF THIS WARRANTY. TO THE EXTENT PERMITTED BY APPLICABLE LAW, BROOKSTONE DISCLAIMS ANY AND ALL STATUTORY OR IMPLIED WARRANTIES, INCLUDING, WITHOUT LIMITATION, WARRANTIES OF MERCHANTABILITY, FITNESS FOR A PARTICULAR PURPOSE AND WARRANTIES AGAINST HIDDEN OR LATENT DEFECTS. IF BROOKSTONE CANNOT LAWFULLY DISCLAIM STATUTORY OR IMPLIED WARRANTIES, THEN TO THE EXTENT PERMITTED BY LAW, ALL SUCH WARRANTIES SHALL BE LIMITED IN DURATION TO THE DURATION OF THIS EXPRESS WARRANTY.

Some states disallow the exclusion or limitation of incidental or consequential damages or how long an implied warranty lasts, so the above exclusions or limitations may not apply to you. This warranty gives you specific legal rights and you may also have other rights, which vary from state to state.

Find thousands more
great ideas online

Brookstone[®]

320195

Merrimack, New Hampshire, USA 03054 • 800-846-3000 • Brookstone.com