

Brookstone®

u•Control

SILVER BULLET RC HELICOPTER



EASY-TO-FLY
INDOOR COPTER

⚠ WARNING:

This product may contain small parts which may pose a choking hazard to children.

AGES
8+
AND UP

TABLE OF CONTENTS

Location of Parts and Controls	2-3
Installing the Batteries.....	4
Charging Your Helicopter	5
Flight Check	6
Let's Fly!.....	6
Helpful Hints.....	7-8
Care and Maintenance.....	9
Warnings, Cautions and FCC Information.....	9-11
Warranty.....	13-14

LOCATION OF PARTS

1. Main Housing
2. Stabilizer Bar
3. Main Rotors
4. Main Rotor Screw
5. Tail Section
6. Main Rotor Mechanism
7. Landing Gear
8. Lights
9. On/Off Switch
10. Charging Outlet
11. Channel Indicator

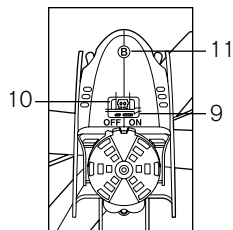
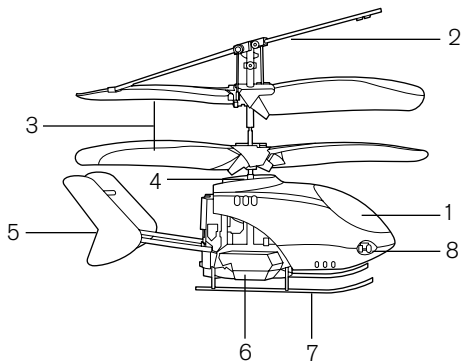

LOCATION OF CONTROLS

1. Remote Control
2. Charging Plug Compartment
3. Charge Indicator Light
4. Channel Switch (A, B, C)
5. Throttle
6. On/Off Switch and Indicator Light
7. Infrared Light
8. Right/Left Turn Control
9. Stabilizing Trim Toggle Button
10. Charging Plug

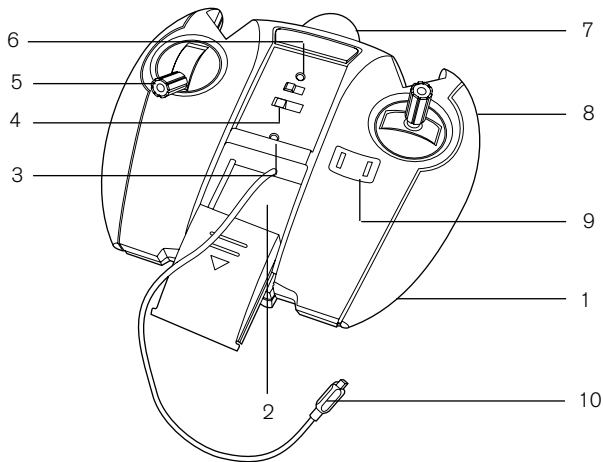

INSTALLING THE BATTERIES

1. Turn the REMOTE CONTROL over to access the battery compartment on the back.
2. Remove SCREW and remove the BATTERY COMPARTMENT COVER (see below).

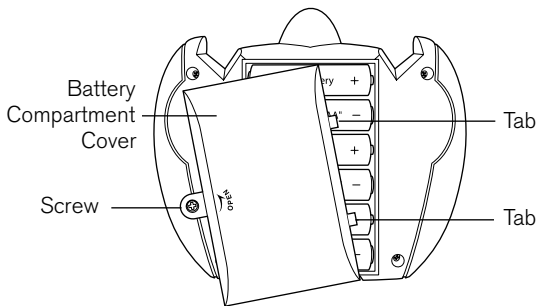

3. Insert 6 AA batteries according to the polarity indicators inside the compartment.
4. Replace the BATTERY COMPARTMENT COVER by sliding the two TABS into the slots in the housing and snapping the cover back into place. Replace SCREW.

CHARGING YOUR HELICOPTER

1. Make sure the ON/OFF SWITCH on the helicopter is set to the OFF position.
2. Slide CHARGING PLUG COMPARTMENT cover on the front of remote control to the open position to access the CHARGING PLUG.
3. Connect the CHARGING PLUG on the controller to the CHARGING SOCKET on the helicopter, making sure the prongs match the plug holes (see Figure 1).
4. Turn the REMOTE's ON/OFF SWITCH to the ON position. The green and red lights on the REMOTE will illuminate, indicating that charging is in process.

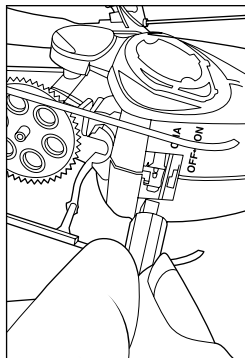

Figure 1

Note: The length of charging time will vary depending on percentage of battery already charged and strength and condition of the AA batteries in the charger. Average charge time is 20-25 minutes.

5. The green charging indicator will shut off when the helicopter is fully charged.
6. Unplug the CHARGING PLUG from the CHARGING SOCKET and store in the CHARGING PLUG COMPARTMENT so it doesn't interfere with the controls.

FLIGHT CHECK

1. Make sure the CHANNEL SWITCH on your REMOTE matches the CHANNEL INDICATOR on the nose of your helicopter. Example: If you have an "A" label on the nose of the helicopter—move the CHANNEL SWITCH to A.
2. Move the helicopter's ON/OFF SWITCH on the helicopter's MAIN HOUSING to ON and make sure the THROTTLE is in the down position.
3. Place helicopter on the floor, pointed away from you, spectators, pets and breakable items.
4. Stand back, and move the REMOTE's power switch to ON.

LET'S FLY!

1. Increase the THROTTLE to full speed until the helicopter leaves the floor, then back the THROTTLE off to approximately half-speed to maintain a steady height while moving forward.
2. Use very slight right and left adjustments with the RIGHT/LEFT TURN CONTROL to allow the helicopter to move to the right and left.
3. If your helicopter is heading for a collision with a spectator or hard object, cut the THROTTLE to prevent damage.
4. Gentle and patient use of the controls will provide the most control of the helicopter.
5. Have fun!

HELPFUL HINTS

Spinning?

You may experience the helicopter wanting to spin in one direction or the other. This is normal and just requires slight trim adjustment to correct. If the helicopter rotates clockwise, hold down the left side of the STABILIZER TRIM BUTTON until it stops rotating. If the helicopter rotates counter-clockwise, hold down the right side of the STABILIZER TRIM BUTTON until it stops rotating. You may need to adjust the trim occasionally during every flight.

Not enough power to lift off?

Your batteries may be low—or the helicopter may need recharging. Recharge and try again.

No control?

1. Are you in the sun? Some infrared signals are interrupted by sunlight, so if you are trying to use your helicopter in a very sunny room, you may experience loss of control. This toy is made to be used indoors. Outdoor use is not recommended.
2. Are you in the wind? Your helicopter is affected by the wind, just like real aircraft. An air conditioner, fan or even an open door can generate enough wind to alter your flight plan. Make sure the air is still when flying.

Helicopter displaying erratic behavior?

1. It is possible that the MAIN ROTOR itself has some debris caught in the mechanism. Check for lint, dust or hair, clear the mechanism gently and try again.
2. If your helicopter isn't lifting off correctly, the problem may be a torn or damaged MAIN ROTOR or STABILIZER BAR. Replace the entire MAIN ROTOR unit with one of the 2 replacements included in the package.
 - Remove the MAIN ROTOR SCREW.
 - Lift the damaged MAIN ROTOR off the MAIN HOUSING.
 - Install a new MAIN ROTOR onto the MAIN HOUSING.
 - Replace the MAIN ROTOR SCREW and tighten securely.

CARE AND MAINTENANCE

- Turn both the helicopter and the remote off before cleaning.
- Wipe helicopter housing clean with a soft, dry cloth.
- Ensure there are no hairs or lint caught between the rotor and the drive shaft. Clean carefully with your fingers or a pair of tweezers.

CAUTION

- For ages 8 and up.
- Keep the helicopter away from face, eyes and hair at all times. Keep fingers away from moving rotors or propellers.
- Recommended for indoor use, and only in rooms without obstacles, breakable objects or fans.
- The charger provided in this package is for charging the helicopter **ONLY**. Do not use any other source to charge the helicopter.
- Do not leave helicopter connected to the charger in storage or for extended periods of time.
- Do not drop in, spray with or submerge unit in water.

CHOKING

WARNING: This product may contain small parts which may pose a choking hazard to children.

FCC INFORMATION

This device complies with Part 15 of the FCC Rules. Operation is subject to the following two conditions:

- 1) This device may not cause harmful interference.
- 2) This device must accept any interference received including interference that may cause undesired operation.

WARNING: Changes or modifications to this unit not expressly approved by the party responsible for compliance could void the user's authority to operate the equipment. Note: This equipment has been tested and found to comply with the limits for a Class B digital device, pursuant to Part 15 of the FCC Rules. These limits are designed to provide reasonable protection against harmful interference in a residential installation. This unit generates, uses and can radiate radio frequency energy and if not installed and used in accordance with the instructions, may cause harmful interference to radio communications. However, there is no guarantee that interference will not occur in a particular installation. If this equipment does cause harmful interference to radio or television reception, which can be determined by turning the equipment off and on, the user is encouraged to try and correct the interference by one or more of the following measures:

- Reorient or relocate the receiving antenna.
- Increase the separation between the equipment and receiver.
- Connect the equipment to an outlet on a circuit different from that to which the receiver is connected.
- Consult the dealer or an experienced radio/TV technician for help.

BATTERY PRECAUTIONS

- Dispose of the old batteries properly. Do not dispose of the old batteries in a fire.
- Do not leave the batteries where a child or pet could play with or swallow them. If the batteries are swallowed, contact a physician immediately.
- The batteries may explode if mistreated. Do not attempt to recharge or disassemble the batteries.
- Use only fresh batteries of the required size and type. Do not mix old and new batteries, different types of batteries, or rechargeable batteries of different capacities.

ONE (1) YEAR LIMITED WARRANTY

Brookstone® warrants this product against defects in materials and/or workmanship under normal use for a period of ONE (1) YEAR from the date of purchase by the original purchaser ("Warranty Period"). If a defect arises and a valid claim is received within the Warranty Period, at its option, Brookstone will either 1) repair the defect at no charge, using new or refurbished replacement parts, or 2) replace the product with a new product that is at least functionally equivalent to the original product, or 3) provide a store credit in the amount of the purchase price of the original product. A replacement product or part, including a user-installable part installed in accordance with instructions provided by Brookstone, assumes the remaining warranty of the original product. When a product or part is exchanged, any replacement item becomes your property and the replaced item becomes Brookstone's property. When a store credit is given, the original product must be returned to Brookstone and becomes Brookstone's property.

Obtaining Service: To obtain warranty service, call Brookstone Limited Warranty Service at 1-800-292-9819. Please be prepared to describe the product that needs service and the nature of the problem. A purchase receipt is required. All repairs and replacements must be authorized in advance. Service options, parts availability and response times will vary. You are responsible for delivery and the cost of delivery of the product or any parts to the authorized service center for replacement, per our instructions.

Limits and Exclusions: Coverage under this Limited Warranty is limited to the United States of America, including the District of Columbia and the U.S. Territories of Guam, Puerto Rico, and the U.S. Virgin Islands. This Limited Warranty applies only to products manufactured for Brookstone that can be identified by the "Brookstone" trademark, trade name, or logo affixed to them or their packaging. The Limited Warranty does not apply to any non-Brookstone products. Manufacturers or suppliers other than Brookstone may provide their own warranties to the purchaser,

but Brookstone, in so far as permitted by law, provides these products “as is.” This warranty does not apply to: a) damage caused by failure to follow instructions relating to product’s use or the installation of components; b) damage caused by accident, abuse, misuse, fire, floods, earthquake or other external causes; c) damage caused by service performed by anyone who is not a representative of Brookstone; d) accessories used in conjunction with a covered product; e) a product or part that has been modified to alter functionality or capability; f) items intended to be periodically replaced by the purchaser during the normal life of the product including, without limitation, batteries or light bulbs; g) any product sold “as is” including, without limitation, floor demonstration models and refurbished items; or h) a product that is used commercially or for a commercial purpose.

BROOKSTONE SHALL NOT BE LIABLE FOR INCIDENTAL OR CONSEQUENTIAL DAMAGES RESULTING FROM THE USE OF THIS PRODUCT, OR ARISING OUT OF ANY BREACH OF THIS WARRANTY. TO THE EXTENT PERMITTED BY APPLICABLE LAW, BROOKSTONE DISCLAIMS ANY AND ALL STATUTORY OR IMPLIED WARRANTIES, INCLUDING, WITHOUT LIMITATION, WARRANTIES OF MERCHANTABILITY, FITNESS FOR A PARTICULAR PURPOSE AND WARRANTIES AGAINST HIDDEN OR LATENT DEFECTS. IF BROOKSTONE CANNOT LAWFULLY DISCLAIM STATUTORY OR IMPLIED WARRANTIES, THEN TO THE EXTENT PERMITTED BY LAW, ALL SUCH WARRANTIES SHALL BE LIMITED IN DURATION TO THE DURATION OF THIS EXPRESS WARRANTY.

Some states disallow the exclusion or limitation of incidental or consequential damages or how long an implied warranty lasts, so the above exclusions or limitations may not apply to you. This warranty gives you specific legal rights and you may also have other rights, which vary from state to state.

Brookstone®

A WORLD OF INNOVATION

Since 1965, people have come to Brookstone to see what's new, discover smart solutions to everyday problems—and have some fun. At Brookstone, we believe there's always a better way to do things. And we created a world of innovation to prove it.

Merrimack, New Hampshire USA 03054 • 800-846-3000 • www.Brookstone.com

627067